



Model LCD-2 (Hot Only)
PN: 120309



Model LCD-2 (Hot Only)
Stainless Front Door
3 Dispensing Handles
PN: 120496



Model LCD-2 Dual (Hot/Cold)
PN: 120441

Installation And Programming Guide

LCD-2 by NEWCO Enterprises

This page intentionally left blank

Section 1 – Installation Instructions and Warranty Policy
Section 2 – Set-Up Programming Instructions
Section 3 – Service Level Programming Instructions

Section 1

Installation Instructions:

Place Machine on a Level Countertop Surface

Connect ¼ Inch Flare water Supply to the Water Inlet located on lower Left Rear of the Machine.

(NEWCO recommends copper tubing for use as water supply to all of our brewing equipment)

Turn water Supply On

Plug or wire brewer to the appropriate voltage circuit as indicated on the **serial tag**.

Locate power switch on the upper right rear of the machine and turn machine power on.

Machine will begin to fill.

If machine has not filled to probe level within 6 minutes it will enter an error mode. Error code E-4 will appear on the display screen. To reset the error and resume filling turn power switch off and then on.

When water in tank reaches probe level, heating cycle will begin.

You are now ready to proceed to Set-Up Programming.

Section 1

WARRANTY

Applies to all equipment manufactured after 2/1/2017. This warranty supersedes all other previous warranties that are currently in manuals.

**Newco warrants equipment manufactured by it for 1 year parts and labor.
Accessories and Dispensers 1 Year parts only.**

Electronic Circuit and Control Boards- 3 years parts, 1 year labor.

Equipment manufactured by others and distributed by Newco- please see original equipment manufacturers warranty, Newco will follow.

These warranty periods run from the date of sale Newco warrants that the equipment manufactured by it will be commercially free of defects in material and workmanship existing at the time of manufacture and appearing within the applicable warranty period. This warranty does not apply to any equipment, component or part that was not manufactured by Newco or that, in Newco's judgment, has been affected by misuse, neglect, alteration, improper installation or operation, relocation or reinstallation, improper maintenance or repair, incorrect voltage applied to the unit at any time, damage or casualty. This warranty does not apply to any equipment failures related to poor water quality, excessive lime and chlorine and non periodic cleaning and descaling. Warranty is null and void if muriatic or any other form of hydrochloric acid is used for cleaning or deliming. In addition, this warranty does not apply to replacement of items subject to normal use including but not limited to user replaceable parts such as faucet seat cups, sight gauge tubes, washers, o-rings, tubing, seals and gaskets.

This warranty is conditioned on the Buyer 1) giving Newco prompt notice of any claim to be made under this warranty by telephone at (800) 556-3926 or by writing to **3650 New Town Blvd, Saint Charles, MO 63301**; 2) if requested by Newco, shipping the defective equipment prepaid to an authorized Newco service location; and 3) receiving prior authorization from Newco that the defective equipment is under warranty.

THE FOREGOING WARRANTY IS EXCLUSIVE AND IS IN LIEU OF ANY OTHER WARRANTY, WRITTEN OR ORAL, EXPRESS OR IMPLIED, INCLUDING, BUT NOT LIMITED TO, ANY IMPLIED WARRANTY OF EITHER MERCHANTABILITY OR FITNESS FOR A PARTICULAR PURPOSE. The agents, dealers or employees of Newco are not authorized to make modifications to this warranty or to make additional warranties that are binding on Newco. Accordingly, statements by such individuals, whether oral or written, do not constitute warranties and should not be relied upon.

If Newco determines in its sole discretion that the equipment does not conform to the warranty, Newco, at its exclusive option while the equipment is under warranty, shall either 1) provide at no charge replacement parts and/or labor (during the applicable parts and labor warranty periods specified above) to repair the defective components, provided that this repair is done by a Newco Authorized Service Representative; or 2) shall replace the equipment or refund the purchase price for the equipment.

THE BUYER'S REMEDY AGAINST NEWCO FOR THE BREACH OF ANY OBLIGATION ARISING OUT OF THE SALE OF THIS EQUIPMENT, WHETHER DERIVED FROM WARRANTY OR OTHERWISE, SHALL BE LIMITED, AT NEWCO'S SOLE OPTION AS SPECIFIED HEREIN, TO REPAIR, REPLACEMENT OR REFUND.

In no event shall Newco be liable for any other damage or loss, including, but not limited to, lost profits, lost sales, loss of use of equipment, claims of Buyer's customers, cost of capital, cost of down time, cost of substitute equipment, facilities or services, or any other special, incidental or consequential damages.

Section 2

Set-Up Programming Instructions:

Open machine cabinet door and locate the 3-switch control panel w/lighted display screen. The temperature will show on the display screen. As shown in **figure 1**.



Step 1. Enter a Programming Mode

Press and hold the center switch labeled “Enter”. After five seconds, the display will flash “Flu” approximately 13 times. Continue to hold in the switch and the temperature will appear. (Release the switch when temp. appears on the display.) As shown in **figures 2 & 2A**.



Step 2. Adjust Temperature

The machine features an adjustable temperature range of 100-200F. Use the + or – switch to scroll to the desired temperature setting. (To turn off the heater press the + or - switch until “OFF” is displayed.) As shown in **figures 3 & 3A**.

Press the “Enter” switch to save and proceed to the next programming option. Either the word “YES” or the word “NO” will appear on the display screen.



Step 3. Enable/Disable BIB Tracking

This machine features the option to track the liquid output of a BIB and then alert the operator when the BIB is empty. (Display will flash the pump number affected and buzzer will beep if enabled.)

To Enable BIB Tracking, use the + or – switch to scroll until the display reads YES. To disable BIB Tracking, use the + or – switch to scroll until the display reads NO. As shown in **figures 4 & 5**. When you have made your selection, press

“ Enter” to save and proceed to the next programming option. On or Off will appear on the display screen. As shown in **figure 6**.



Step 4. Enable/Disable Alarm

This machine features a buzzer alarm that will sound to notify the operator when one of the following three things has occurred:

- BIB Tracking has detected an empty BIB (See step 4)
- A machine malfunction has been detected
- The machine has completed a sanitization cycle

This feature offers the option to disable the buzzer alarm.

To enable the alarm, use the + or – switch to scroll until the display reads ON.

To disable the alarm use the + or – switch to scroll until the display reads OFF. See **figure 7**. When you have made your selection, press “Enter” to save and proceed to the next programming option. SEL will appear on the display screen. See **figure 8**.

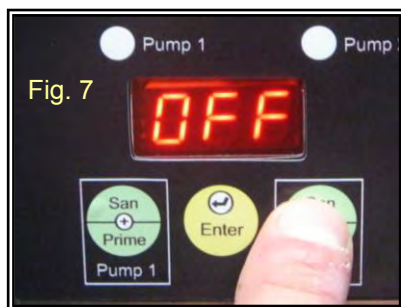

Step 5. Program Selector Switches

This machine features a 7-selector switch control panel. The center switch on the control panel is reserved for Hot Water Dispense. The remaining 6 switches can be programmed to deliver a drink from either of the product BIBs or can be programmed to create a drink by blending product from both BIBs.

In order to proceed with switch programming, it is first necessary to familiarize you with pump orientation.

Pump 1 is mounted on the left side of the mixing chamber. (When facing the machine from the front.) Pump 1 supports the product BIB that is installed directly above it.

Pump 2 is mounted on the right side of the mixing chamber. Pump 2 supports the product BIB that is installed directly above it.

To program a selector switch to create a drink using the product on the left, enter the pump speed from Chart A below in to Pump 1 and set the speed of Pump 2 to :00

Program selection single product:

To program a selector switch to create a drink using the product on the right, enter the pump speed from Chart A in to Pump 2 and set the speed of Pump 1 to 0:00.

Program selection blend products:

To program a selector switch to create a blend using both products, set the speeds of Pump 1 and Pump 2 using Chart B as a guideline.

High Flow Rate Ratio Chart (Use this chart if the unit is a high flow unit.) See page 8 for visual of the nozzle.

Ratio	Chart A	Chart B	Chart C
	Pump Speed Setting	Pump Speed Settings	Pump Speed Settings
	Single	(Blend 50/50)	(Blend 25/75)
45:1	9	4/4	1/6
40:1	11	5/5	1/8
35:1	13	6/6	1/10
30:1	15	7/7	2/11
25:1	19	8/8	3/13
20:1	-	11/11	-
15:1	-	17/17	-
14:1	-	18/18	-

Low Flow Rate Chart (Use this chart if the unit is a low flow unit.) See page 8 for visual of the nozzle.

Ratios	Chart A Pump Speed Setting	Chart B Pump Speed Settings
	(Single)	(Blend)
45:1	5	1/1
40:1	6	2/2
35:1	7	2/2
30:1	9	3/3
25:1	11	4/4
20:1	15	6/6
15:1	24	9/9

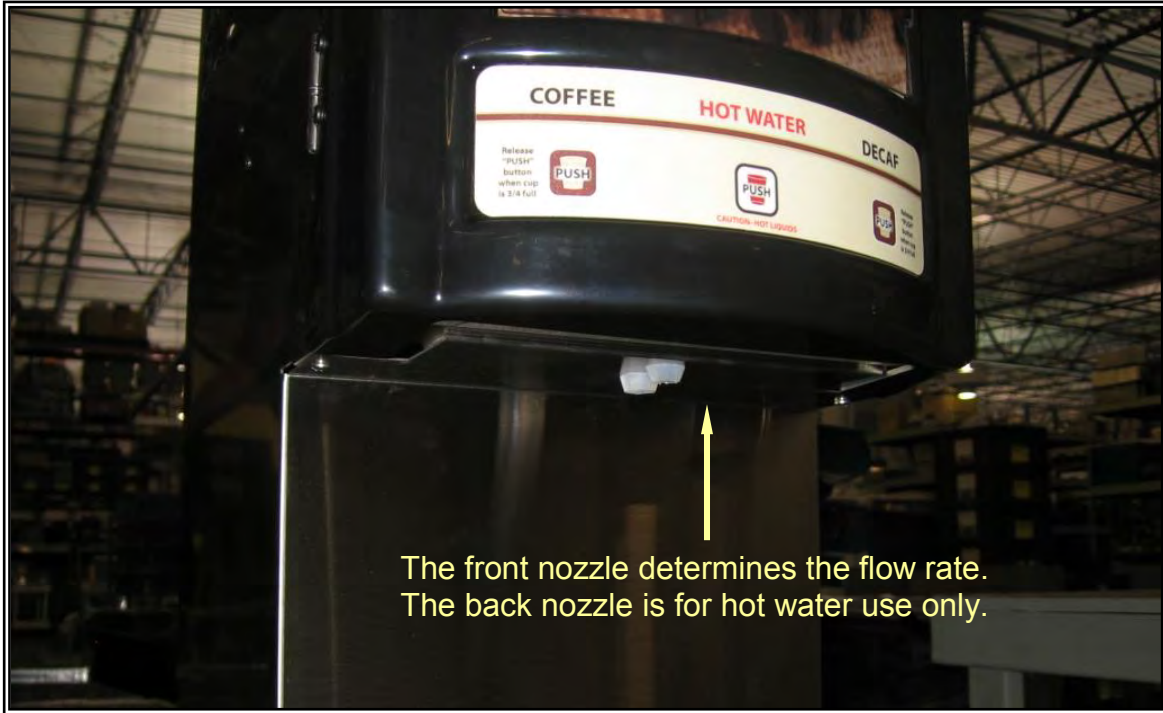

800203, Low Flow Nozzle
(Small Diameter Opening)



800204, High Flow Nozzle
(Large Diameter Opening)

To Program a selector switch:

- On the 7-selector switch control panel, press the switch that you want to program. The display will change to identify the switch that you have chosen. (b01 thru b06 are the switch identifiers.) See **figures 9 & 10**.

NOTE: The optional liquid coffee dispensing unit with a stainless front door uses handles. These act as buttons for programming. Pulling and holding down the handle acts in the same way as pressing a button. The center handle is for hot water only and cannot be used for programming.



- Press Enter. The number "1" and the current speed for pump 1 will appear in the display. As shown in **figure 11**.



- Using the + or - button to scroll, set Pump 1 speed for the desired ratio using chart A above as a guide. (If blending two products, use chart B as a guide.) As shown in **figure 12**.



- Press, “Enter” to save and proceed to set Pump 2. The number “2” and current pump speed setting for Pump 2 will appear on the display. As shown in **figure 13**.



- Using the + or – button to scroll, set Pump 2 speed for the desired ratio using chart A above as a guide. (If blending two products, use chart B as a guide.) Refer to **figure 12**.
- **NOTE: (FOR LCD-2 Dual Only)** Press “Enter” to save. “HOT” or “CLd” will appear on the display. This entry chooses whether the selected button will use ambient temperature water (“CLd”) from the water supply line or hot water (“HOT”) from the tank for dispensing. Use the + or – button toggle between “HOT” or “CLd.”

- Press “Enter” to save and proceed with the set-up program. A time value (min: sec) will appear in the display. If the switch that you are programming has been set in a portion control mode, the value will represent the current dispense time for the switch. If the switch is in a continuous flow (push and hold) mode, the time value will be 0:00 Shown in **figure 14**. To set portion control, in this mode, use the + and – keys to enter the time of dispensing.



- Press “Enter” to save and proceed to the next set-up programming option. SEL will appear on the display.
- Continue with switch programming by repeating steps 1 thru 7.
- When switch programming is completed, continue to press and release the “Enter” button until the display returns to 3 dashed lines. The machine will be in a normal operating mode.

Procedure: Setting Portion Control in Normal Run Mode

To program a switch for portioned controls, while in run mode, dispense time must start at "0:00" (See figure 14) to do this:

1. Place the desired cup (or carafe) under the dispense head.
2. Press and hold the "Enter" switch.
3. Press and hold the selector switch that you want to program.
4. After two seconds release the "Enter" switch.
5. When the cup (or carafe) is filled to the desired level, release the selector switch.
6. The switch is now programmed to automatically fill to that level.

Procedure: Return Switch to Continuous Flow Mode

1. Enter program mode by pressing and holding the "Enter" switch for five seconds.
2. Press and release the "Enter" switch until SEL appears on the display.
3. Press the selector switch that you want to return to continuous flow mode. (The switch identifier will appear on the display.)
4. Press and release the "Enter" button 3 times. (The selector switch timer will appear on the display.)
5. Using the + and – switches, scroll until the selector switch timer reads 0:00
6. Press and release the "Enter" switch until 3 dashed lines appears on the display.

The switch is now in a continuous flow (push and hold) mode.

Procedure: Disable a Selector Switch

1. Push and hold the "Enter" switch for 8 seconds to enter a programming mode. The current temperature setting will appear on the display. (Refer to: Page 3 Programming Mode.)
2. Press and release the "Enter" switch repeatedly until SEL appears in the display.
3. Press the selector switch that you have chosen to disable.
4. Press and release the "Enter" switch. Pump 1 speed will appear in the display.
5. Using the + or – button to scroll, set Pump 1 speed to 0.00
6. Press and release the "Enter" switch. Pump 2 speed will appear in the display.
7. Using the + or – button to scroll, set Pump 2 speed to 0.00
8. Press and release the "Enter" switch until three dashed lines appear in the display. The switch is disabled.

Section 3

Service Level Programming Functions:

Sanitizing Instructions

Press the + switch to enter sanitize mode. SAN will appear in the display. (As shown in figure 15)

Remove the product BIBs from the machine and connect a BIB of sanitizing solution to the PUMP 1 BIB connector. (The one on the left (as you face the machine from the front.)



Place an empty decanter or other vessel under the dispense area of the machine.

Press the “Pump 1” (+) switch on the display panel to begin sanitizing.

When sanitizing cycle ends (2.5 minutes total: pump 45 sec., dwell 90 sec., & water 15 sec.), the buzzer alarm will sound 3 times if enabled during the “Set-Up Programming”. The machine will automatically advance to “Pump 2”. (Pump 2 will duplicate Pump 1’s process.)

Disconnect the BIB of sanitizing solution from the Pump 1 BIB connector and connect it to the Pump 2 connector.

Press the “Pump 2 (–) switch on the display panel to begin sanitizing.

When sanitizing cycle ends, remove the sanitizing solution and replace the products. The machine will automatically advance to the Prime Pumps mode.

To Prime: Press and hold the “Pump 1” (+) switch until a steady stream of product flows from the dispense area into the vessel.

Press the “Enter” switch to advance to Pump 2.

Press and hold the Pump 2 (-) switch until a steady stream of product flows into the vessel.

Press and release the “Enter Switch until 3 dashed lines appear in the display.

Discard the contents of the decanter or vessel.

Prime Pump Feature:

This feature allows you to enter directly into a Prime Pump mode without sanitizing.

Press the - switch to enter the Prime Pump mode.

Follow the same Prime Pump procedures from Sanitizing Instructions.

BIB Counter Auto-Reset Feature:

If enabled during the “Set-Up Programming” of the machine a buzzer alarm will sound once per second to indicate that a product BIB is empty.

Entering into a Prime Pump mode turns off the alarm.

Only reset the pump shown on the display.

BIB tracking is automatically reset when the pump is primed.

Product Installation Procedures:

- Open the cutout on the product box and position the BIB fitment into the slotted area as shown in **figure 1**.



Remove the plastic insert from the BIB fitment as shown in **figure 2**.



Using finger and thumb only to prevent over-tightening, thread the BIB connector on to the BIB fitment until seated as shown in **figure 3**.



Place the product in the storage compartment as shown in **figure 4**.



Position the tubing as shown in **figure 5**



Cleaning & Sanitizing Instructions:

Remove product from storage area and disconnect BIB connectors as shown in **figures 1 & 2**.

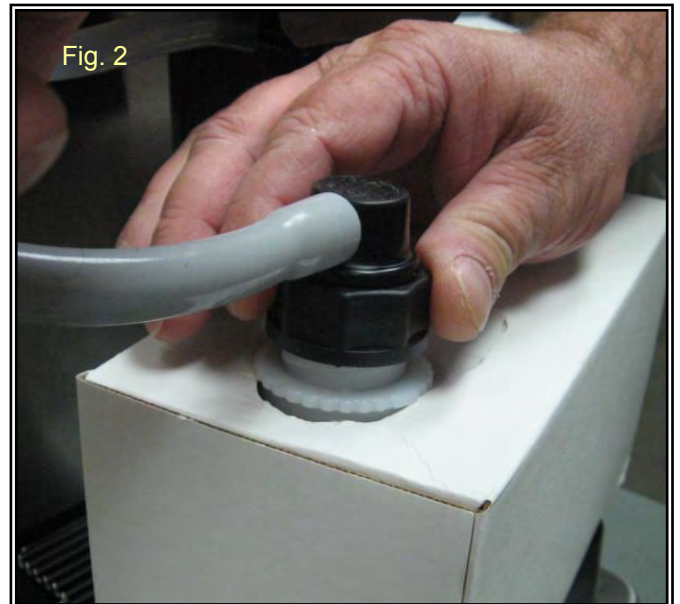
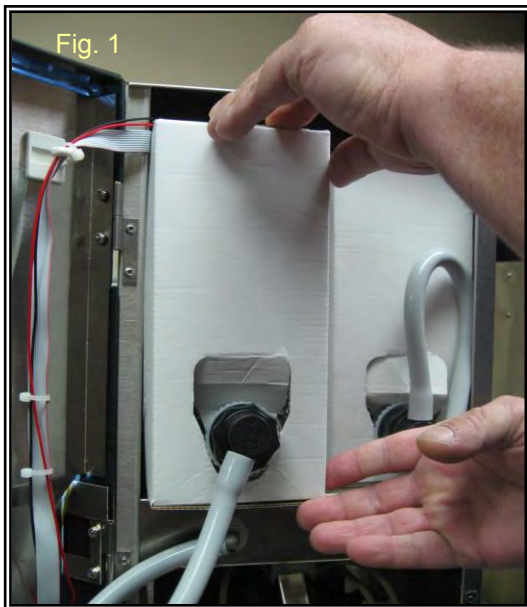

Place an empty container in the dispense area of the machine as shown in **figure 3**.

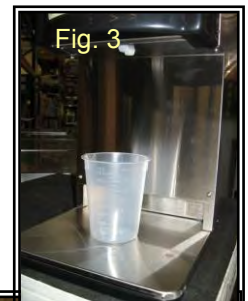

Connect the sanitizing solution to the BIB connector for Pump 1 (the connector on the left as you face the machine from the front) and place sanitizing BIB on the product shelf as shown in **figures 4 & 5**



Press the Pump 1 button to enter sanitizing mode as shown in **figure 6**.



Press the Pump 1 button again to begin sanitizing. Sanitization cycle will run for 2-1/2 minutes. Buzzer alarm will sound 3 beeps when cycle is complete.



Disconnect sanitizing solution from Pump 1 and connect to the BIB connector for PUMP 2 as shown **figures 7 & 8**.

Press Pump 2 button to begin sanitizing Pump as shown in **figure 9**.

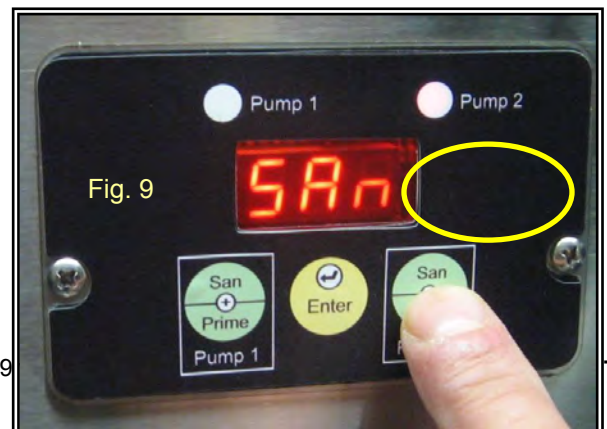

When cycle is finished remove sanitizing solution and reinstall products as shown in **figure 10**.



Press and hold Pump 1 button until product flows from dispense head to prime pump 1 as shown in **figure 11**.



Press enter to proceed to Pump 2 as shown in **figure 12**.

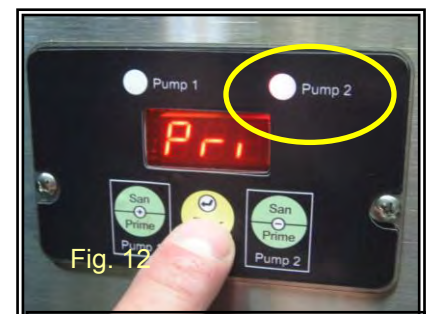

Press and hold Pump 2 button until product flows from dispense head to prime Pump 2 as shown in **figure 13**.

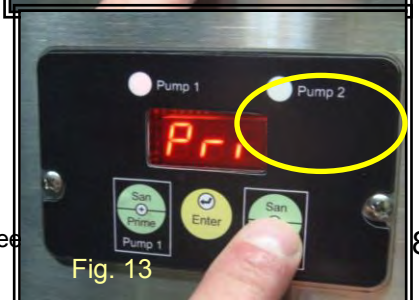

Press enter to return to the normal operating mode as shown in **figure 14**.

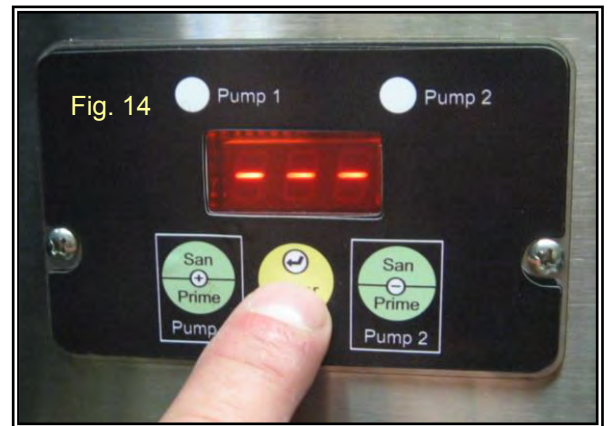

Flushing Instructions:

Flush the mixing chamber by pressing and holding the “Enter” button for 5 seconds until “FLU” appears on the display. Release the “Enter” button. Press and hold either the + or – button to flush the mixing chamber with water. (Refer to: Page 3 Figure No. 2.)

Flush Product & Type of Fittings:



900044: Easy Clean Flush Solution



400137: QCD Fitting



107117: Scholle Fitting

Error Messages:

Error Number	Description	Cause	What to Check
tHU/ tHL	Thermistor warning – immediately upon detection the machine will beep twice and show the warning message for a minute as well as turn on the right most upper dot on the display. This dot will stay on to signify there is a thermistor out. Also upon power up the machine will beep twice and show the warning message for a short period of time and turn on the high dot if the warning conditions are present	Resistance extremely high from upper or lower thermistor will cause or the resistance extremely low from upper or lower thermistor will cause a tHU or tHL warning for the thermistor that sees the condition and causes the control board to switch from watching the lower to the upper thermistor. If both the upper and lower resistors fail then we flag a thermistor ErC error	This warns you that 1 thermistor has failed. Nothing is required at this time as the upper thermistor has taken over but ordering a replacement thermistor is advisable
Er3	Heater Run Error	Water did not heat within timeout period. Timeout period is 240 seconds which is reloaded whenever the heater is off or the fill valve is on	Check element for short and proper resistance. Replace if bad.
Er4	Tank Fill Error	Water did not reach probe in timeout period of 6 minutes for initial fill and 1 minute during normal operation. The 6 minute fill time is reloaded if no key is pressed within 24 hours	Check valve function and flow rate. Replace valve or increase flow rate. Check probes for excess scale.
Er5	Comm Error	Serial communication error to/from non-volatile memory (EEPROM).	Hold down the enter key to enter Machine Set up mode pressing the enter key to cycle through all options then exit mode. This resets all the defaults. If the error still occurs then replace main board.
Er7	Open Motor Circuit - The motor errors (Er7 and Er8) do not cause a system error and will not shut down the machine. Immediately upon detection the machine will beep twice and show the error message. Every	Open motor circuit. Pump 0 or pump 1.	Retry pump if the error still occurs then check harness/motor continuity. Replace if defective.

	time the key is pressed to activate a dispense motor it clears the error and allow another attempt to be made. If this error occurs the dump valve still will release water.		
--	--	--	--

Error Messages Cont'd:

Er8	Bad (Open) Motor Driver - The motor errors (Er7 and Er8) do not cause a system error and will not shut down the machine. Immediately upon detection the machine will beep twice and show the error message. Every time the key is pressed to activate a dispense motor it clears the error and allow another attempt to be made. If this error occurs the dump valve still will release water.	Bad/open motor driver. Pump 0 or pump 1.	Retry pump if the error still occurs then replace main board.
Erb	Dry Firing Tank – the tank is empty but the heater is on.	The control board has either seen a rise in temperature of 1 degree a second, for 5 seconds or has seen the temperature rise to 215°F or above	The unit has been in the intent to brew timeout for an extended period of time, allowing the tank to evaporate to the point where there is little water in the tank
ErC	Thermistor Error	Resistance extremely high from upper or lower thermistor will cause or the resistance extremely low from upper or lower thermistor will cause a tHU or tHL warning for the thermistor that sees the condition and causes the control board to switch from watching the lower to the upper thermistor. If both the upper and lower resistors fail then we flag a thermistor error	Check/replace thermistor.

Dimensions & Electrical Specifications:

LCD-2 LIQUID COFFEE DISPENSER

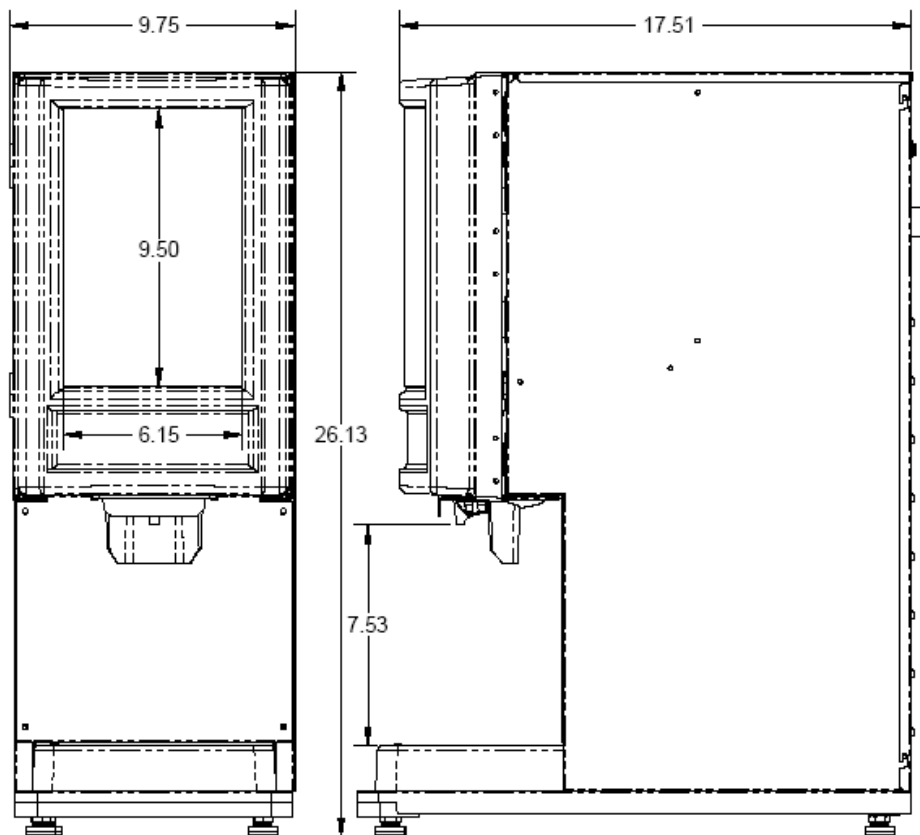

****Electrical Specs****

**PN: 120309, LCD-2
120V 1750W
15 Amps**

**PN: 120354, LCD-2
120V/240V 3500W
15 Amps**

Electrical Schematics:

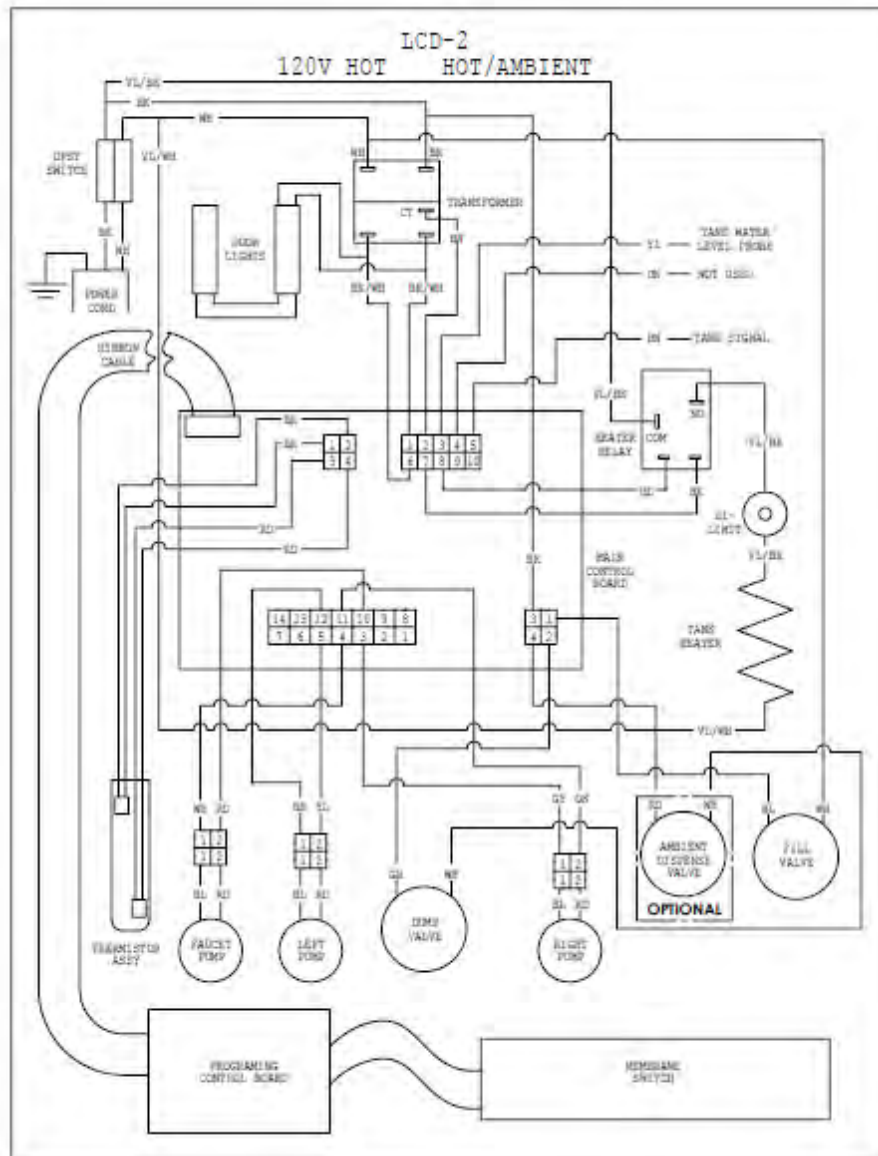

Electrical Schematics:

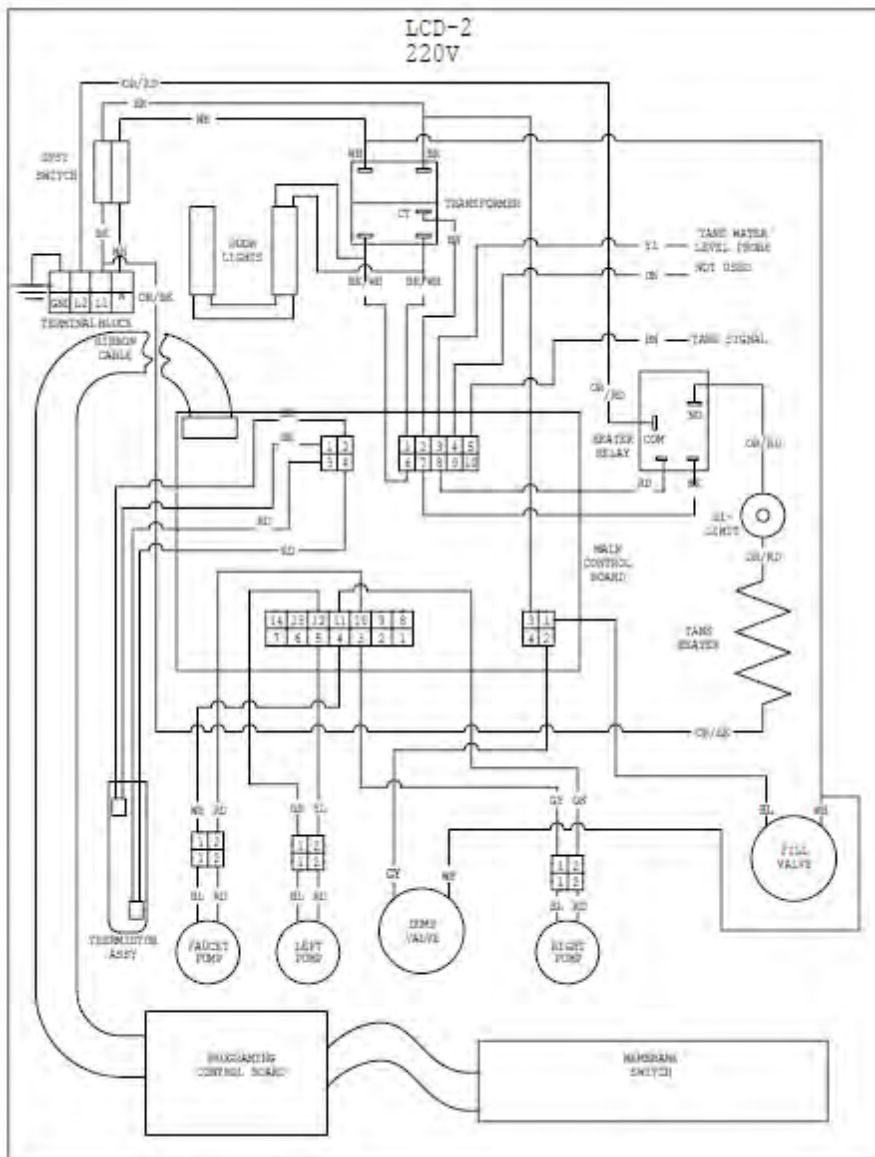

Electrical Schematics:

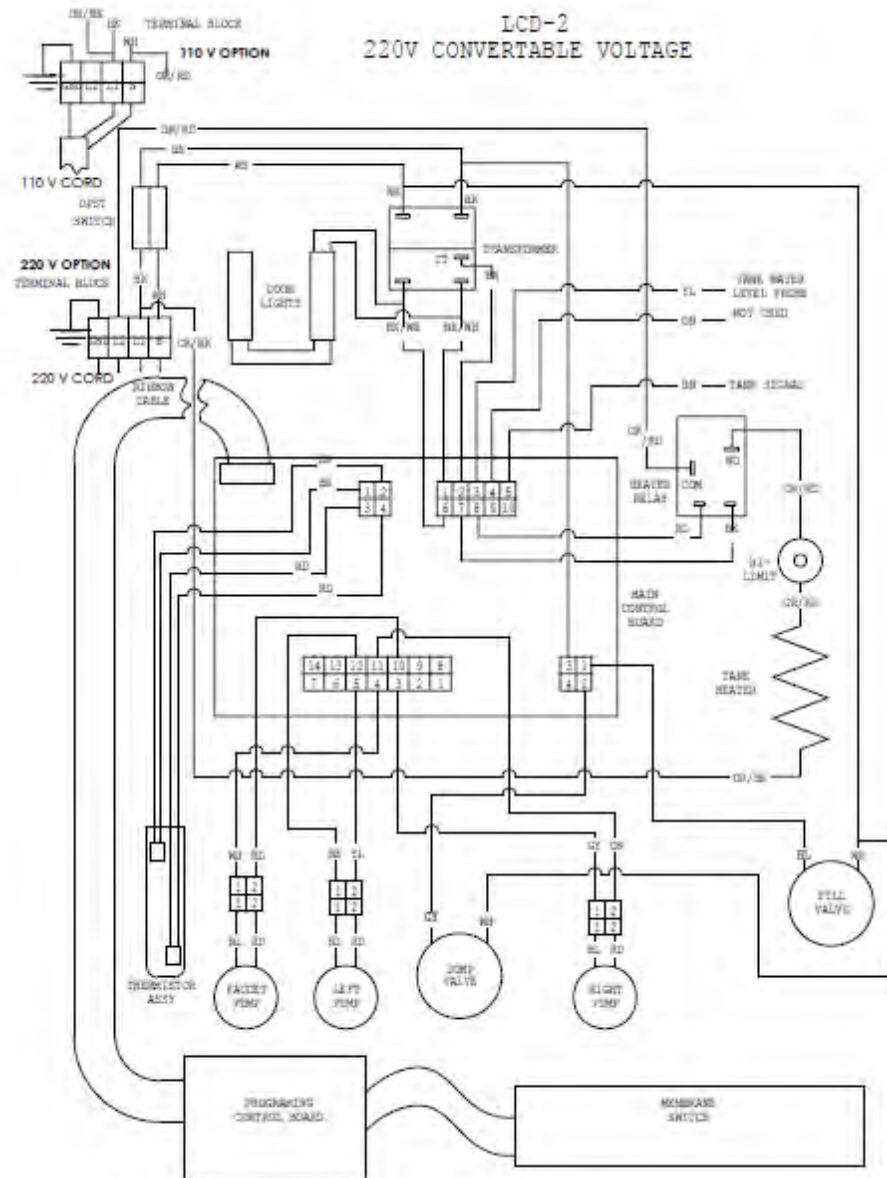

This page left intentionally blank

This page left intentionally blank

This page left intentionally blank